

SLOTS ON FLANGE APPEAR ON PART NO. R10L5.5-B THROUGH R16L16-B ONLY

PART NO.	NOMINAL BRG. I.D.	BEARING I.D. +.001/-0.000	MAXIMUM SHAFT DIAMETER	HOUSING BORE ±.0005	BEARING LENGTH "L" +.000 -1/64	RADIUS "R" MAX.	FLANGE	
							DIA. ±1/64	"T" +.000 -.005
R3L3-B	3/16	.1885	.1875	.2345	3/16	.010	5/16	.025
R4L4-B	1/4	.2510	.2500	.2970	1/4		13/32	
R5L5-B	5/16	.3135	.3125	.3750	5/16		1/2	
R5L7-B					7/16			
R5L10-B					5/8			
R6L6-B	3/8	.3760	.3750	.4375	3/8		19/32	
R6L11-B					11/16			
R7L7-B	7/16	.4385	.4375	.5000	7/16		21/32	
R8L3.5-B	1/8	.5010	.5000	.5625	7/32		3/4	
R8L5.5-B					11/32			
R8L8-B					1/2			
R10L5.5-B	5/8	.6260+.003	.6250	.6875	11/32		15/16	
R10L7-B		.6260			7/16			
R10L10-B					5/8			
R10L14-B					7/8			
R10L18-B					1-1/8			
R12L12-B	3/4	.7510	.7500	.8125	3/4	1-1/8		
R12L18-B					1-1/8			
R14L7.5-B	7/8	.8760	.8750	.9375	15/32	1-5/16		
R14L14-B					7/8			
R16L16-B	1	1.0015+.0015	1.0000	1.0940	1	.020	1-1/2	.045

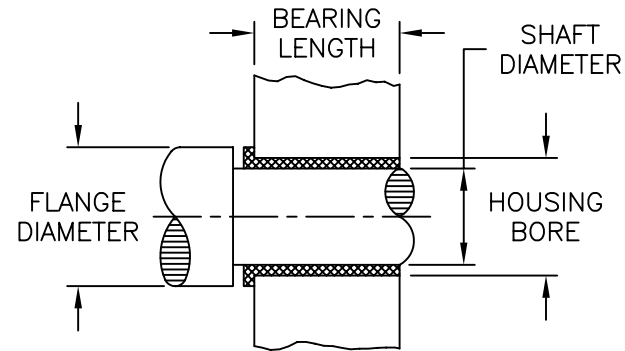
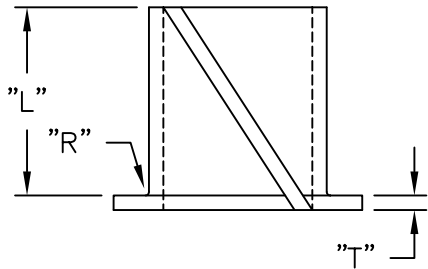

NOTES:

1. MATERIAL: NYLON 6/6 (RMS-48).
2. COLOR: WHITE.
3. MAX. CONTINUOUS NON-LUBRICATED OPERATION: 500 RPM.

REV	DESCRIPTION	ENGR	DATE
D	UPDATED PRINT AND ADDED NOTE 3.	SM	02.25.02
C	REMOVED R8L12-B; CHANGED FILE NO.	SM	11.09.01
B	SLOTS ADDED TO ISOMETRIC	PB	092394
A	P/N R10L18-B WAS R10L16-B	PB	072594

TITLE: MODEL B: FLANGED SLEEVE BEARING W/OUT POSITIONING KEY				DWG IN INCHES		FINAL	
TOLERANCES UNLESS NOTED .XX=±.010 .XXX=±.005 FRAC=±1/64 ANG=±1°		FILE # RXLX-A,B,C	DWN: P.B.	APP:	PART #		PRINT TYPE
		MAT'L: SEE NOTES	DT: 05-06-94	DT:	SEE TABLE		CA
		RE: RICHCO, INC.	RICHCO INC. PO BOX 804238, CHICAGO, 60680 (773) 539-4060				